

GRAYWATER SYSTEM GUIDELINES FOR OUTDOOR IRRIGATION

MENDOCINO COUNTY PLANNING & BUILDING and ENVIRONMENTAL HEALTH

INTRODUCTION

Overview of Guide:

Why send your laundry wash water to a sewage treatment plant when you can use it to water plants and trees in your yard instead? Certain types of wastewater are clean enough for outdoor subsurface irrigation. That's why many Californians use their laundry and shower water to keep their landscapes green, even during times of drought.

The *Mendocino County Graywater System Guidelines for Outdoor Irrigation* is an educational resource for homeowners and professionals who want to install residential graywater systems for subsurface outdoor irrigation. In this guide, you'll learn about the benefits of graywater, when and where to use it, and when a permit is required.

The guide provides methods for designing and installing a clothes washer system (also known as a laundry-to-landscape system). The methods described in this guide may not be the only procedures for designing and installing systems that meet current requirements. Each homeowner's circumstances are different; you must ensure that a graywater system on your property is designed and installed safely, is consistent with applicable code requirements, and is operated in a manner that causes no harm or damage to yourself or neighbors. If at any time you have doubts about installing a graywater system, please consult a qualified Site Evaluator or plumber.

What is Graywater?

- Graywater is water from clothes washing machines, showers, bathtubs, and bathroom sinks. It is water that contains some soap but is clean enough to water plants.
- Water from toilets, kitchen sinks, dishwashers and wash water from diapers is not considered graywater in California.
- Graywater is not the same as recycled water, which is highly treated wastewater that is used in applications such as irrigation and toilet flushing.
- A Graywater System **cannot replace** a septic system or city sewer connection.

Benefits of Graywater

Reusing graywater is an important water saving practice. Benefits of using graywater instead of potable water for irrigation include:

- Decreases potable water use by 16 to 40 percent, depending on the site (Cohen 2009).
- Decreases water and wastewater utility bills.
- Provides an alternate source of irrigation water while reserving treated potable water for high-quality water needs like drinking and showering.

Graywater Basics

Graywater is a unique source of water and must be used differently from potable water and rainwater. These are some basic guidelines for residential graywater systems:

- **Do not store graywater more than 24 hours.** If you store graywater, the nutrients in it start to break down and create bad odors.
- **Minimize contact with graywater.** Graywater can contain pathogens. All systems should be designed so that water absorbs into the ground and is not accessible to people or animals.

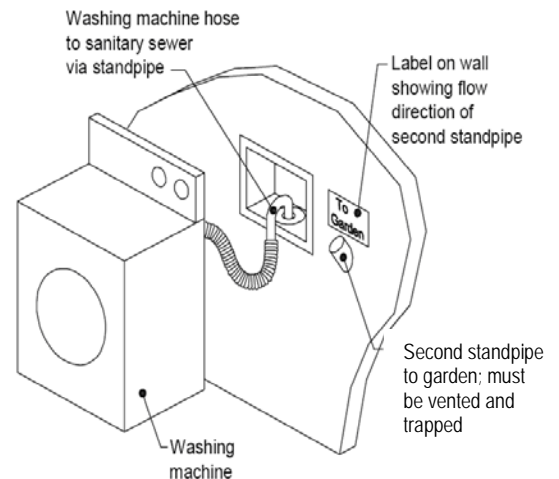

Figure 1: Typical clothes washer system.

- **Do not use graywater for irrigating food crops** such as root vegetables or edible parts of food crops that touch the soil.
- **Disperse graywater into the ground** and cover irrigation field with at least 2" of mulch, soil, rock or other approved material.
- **Keep your system as simple as possible.** Avoid pumps and filters that need maintenance. Simple systems last longer, require less maintenance, use less energy and cost less.
- **Install a valve at a convenient location** to allow for easy switching between the graywater system and the sewer system.
- **Do not allow water to pond or run off your property.** Ponding graywater can provide opportunities for mosquitoes to breed and human contact. Your graywater system must be located entirely on your property, and cannot runoff to other properties.
- **Match the amount of graywater directed to your plants with their irrigation needs.** You need to know how fast water absorbs into your soil to properly design your system.

Another Benefit of using graywater – it connects us to our water supply! Understanding where our water comes from and where it goes helps us become conscious of our water usage.

Graywater Regulations

Graywater use is legal in California. In August 2009 California's graywater regulations changed, allowing for lower-cost graywater systems to be installed legally, including some without the need for a plumbing or building permit. A permit is not required for *Clothes Washer Systems* (laundry-to-landscape) that meet the conditions listed in the next section, "When a Permit Is Not Required." For information on systems that do require permits, see "When a Permit Is Required." California regulations for residential graywater systems can be found in Chapter 16A of the California Plumbing Code.

When a Permit Is Not Required

You can install a graywater system **without** a permit if you meet **all** of the following requirements:

- Graywater comes from the washing machine only.
- Graywater system does not alter the household plumbing (graywater is accessed from the hose of the machine, not by cutting into the plumbing).
- Graywater system does not modify structure.
- Graywater system is for one- or two-family dwelling.

Graywater system follows 12 guidelines set forth in the California Plumbing Code (see the guidance document titled California Graywater System Requirements at: www.co.mendocino.ca.us/hhsa/chs/eh/landuse.htm).

- A plot plan of your clothes washer system has been submitted and approved by the Mendocino County Division of Environmental Health.

When a Permit Is Required

You **need** a plumbing permit and potentially a building permit for a graywater system that includes **one or more** of the following conditions:

- Graywater system collects water from showers, sinks, or baths.
- Graywater system alters the plumbing. If you cut into the drainage plumbing to access the graywater, you must obtain a permit from Planning & Building Services.
- Graywater system modifies structure.
- Graywater system is installed in a building that is not a one- or two-family dwelling.
- Graywater system includes a pump (other than the washing machine's internal pump) or a tank.

Developing a Graywater System

Graywater systems can range from very simple to very complex. Follow these steps to create a well-functioning and safe system.

1. **Start with water conservation!** Saving water is the low cost and environmentally friendly place to begin. You may find that your landscape doesn't need the amount of water you've been giving it. There are also easy ways to greatly reduce the amount of water used in your household.
2. **Determine which fixtures in your home are candidates for graywater capture.** Clothes washing machines are the easiest place to begin, and a graywater system using only water from a clothes washer may not require a permit.
3. **Adding other acceptable fixtures to your graywater system** such as the shower, bathtub or the bathroom sink will require a permit from Planning & Building Services.
4. **Estimate the quantity of graywater produced** by your chosen source(s) using the *Estimating Graywater Flows* section on page 4 of this manual.
5. **Determine your soil type** by conducting a *soil ribbon test* (see pg. 5) and/or sending soils for laboratory analysis (optional).
6. **Determine the size of your graywater *Irrigation Field*** using your estimated graywater flow and soil type.
7. **Submit Permit Application** (if applicable).
8. **Submit a plot plan to the Mendocino County Environmental Health Division.** Even though a permit is not required for a *Clothes Washer System*, you are still required to submit a plot plan and details about the system to Environmental Health.
9. **Install your system.** Once your plans are reviewed and approved, and a permit is issued by Planning & Building Services (if applicable), find an installer or install the system yourself.
10. **Remember to label the system** including the 3-way valve and all above-ground graywater pipes.
11. **Schedule the Final Permit Inspection** (if applicable).
12. **Operate & Maintain your system.** An Operations & Maintenance manual must stay with the property for the life of the system. A Sample Operation & Maintenance Manual can be found at: <http://www.co.mendocino.ca.us/hhsa/chs/eh/landuse.htm>

SIZING Your Graywater System

OVERVIEW:

There are three steps for sizing your graywater system. It is important to follow these steps so that you can design a system that has a properly sized *irrigation field*. Remember, California state law requires that graywater irrigation systems never cause ponding or runoff.

- STEP 1: Estimate your graywater flows.** When designing your *Clothes Washer System*, there are two different methods for estimating your graywater flows: the California Code Method and the Irrigation Calculation Method. Both methods are explained on the next page. Permitted graywater systems that incorporate fixtures other than your clothes washer are required to use the California Code Method.
- STEP 2: Estimate the soil absorption capacity of your soils** using a soil ribbon test (explained on page 5) or a laboratory analysis (optional).
- STEP 3: Calculate the size of your *irrigation field*.** Use your estimated graywater flows from Step 1 and your soil absorption calculations from Step 2 to determine the necessary size of your irrigation field (see page 6).
- STEP 4: Record findings of Steps 1 to 3** in the Operations & Maintenance Manual for your system. Be sure to show your calculations when recording your findings.

STEP 1: Estimate your Graywater Flows

California Code Method

(Based on CCR Title 24, Part 5, Chapter 16A)

For the CA Code Method, calculate the number of occupants using the following calculation, not the number of people actually living in your home.

Number of Occupants: 2 occupants in the First Bedroom, 1 occupant in Each Additional Bedroom

Graywater flow per occupant: 15 gallons per day per occupant (gpd/occupant) for a washing machine

Total Estimated Graywater Flow: Number of Occupants x Graywater flow per occupant = Total Estimated Graywater Flow

Example: 3 Bedroom Home

Number of Occupants = 4

Graywater flow per occupant = 15 gpd/occupant

Total Estimated Graywater Flow = 4 occupants x 15 gpd/occupant = 60 gpd

Irrigation Calculation Method: Irrigation calculations are important to make for all systems as they help ensure your plants will not get over or under-watered. This method can be used in place of the CA Code Method above for Clothes Washer Systems only.

Washing Machine (weekly flow): 20 gallons/load* x 3 loads per week = 60 gallons per week

Washing Machine (daily flow): 20 gallons/load* x 3 load(s) per day = 60 gallons per day

* See your machine specifications to determine how many gallons are used per load. The numbers used here are for example only.

Performing these calculations for your specific household fixtures yields the most accurate estimate of the amount of graywater available for your plants, but does not consider future changes. Volumes can vary if the size or habits of your household change over time, or if a new owner moves in. If you sometimes do five loads of laundry in one day, rather than spread them out over the week, consider this when you design and operate your system.

STEP 2: Estimating the Absorption Capacity of Your Soils

Understanding the ability of your soil to absorb water is critical for designing your graywater system and sizing your landscape irrigation field. The irrigation field must be sized to allow the graywater to soak into the soil without ponding or runoff.

Different types of soil absorb water at different rates. Sandy soils absorb water more quickly than clay soils. To learn the basics about the soils in your yard, conduct a simple soil ribbon test by following the flow chart below.

Soil Ribbon Test



Figure 5. Prepare soil for the ribbon test by moistening and kneading.

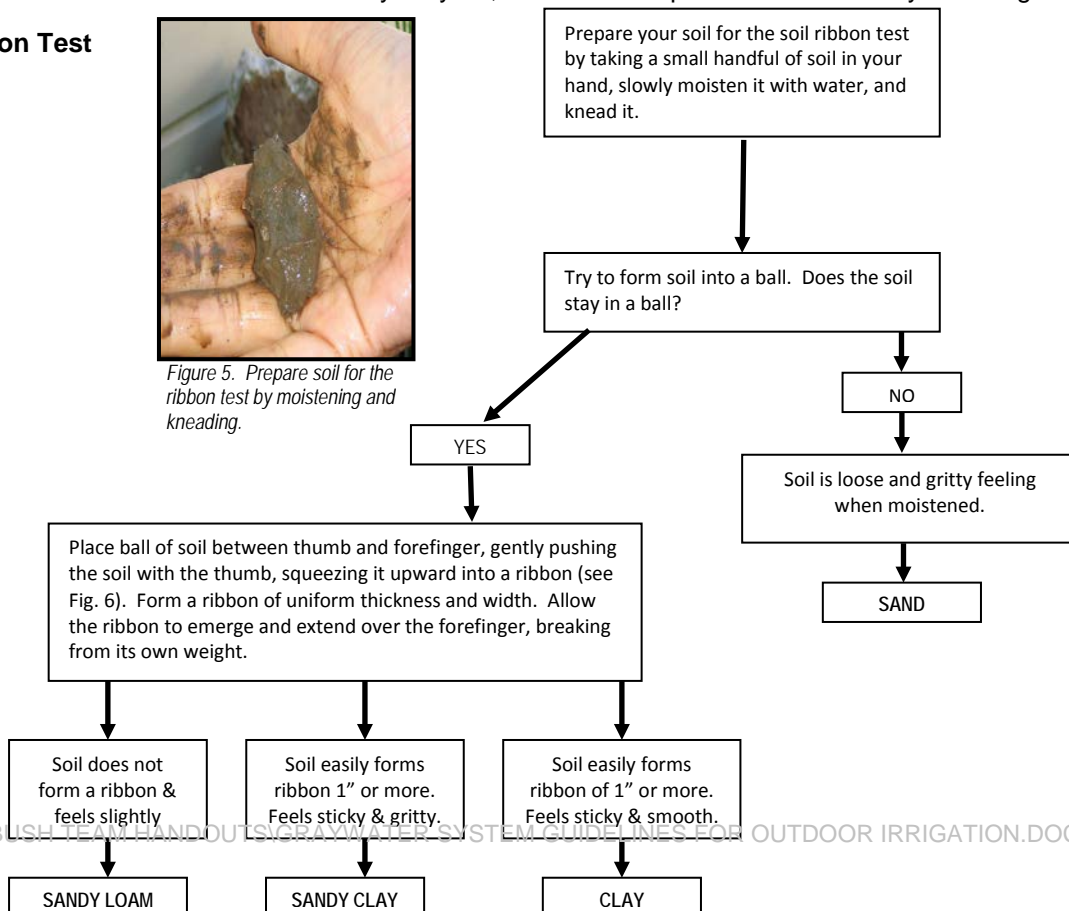

Figure 6. Squeeze soil, pushing

Drainage Test (Optional)

If you plan to use graywater to irrigate sections of your yard that you already irrigate, you may not need to conduct the drainage test. The test will provide information about how well water absorbs in a particular location. Deeper soils can differ from surface soils, and hardscape (such as an old cement patio) might be buried under your yard. If you are unsure how water absorbs into the soil, a drainage test can help identify appropriate locations for irrigating with graywater. Remember, ponding and runoff of graywater is never allowed. If ponding or runoff occurs, you will need to redesign your system.

1. Dig a hole, approximately one foot deep, in the area where you plan to irrigate with graywater. Insert a ruler or stick marked with inches into the hole.
2. Fill the hole with water and let it soak in. Repeat this several times so that the surrounding soil is saturated when you take your reading.
3. Fill the hole with water again; this time record how long it takes for the water level to go down a few inches. If it drains approximately one inch per hour or faster, you have adequate drainage for irrigating the area with graywater.
4. If it takes longer than two hours for the water level to go down one inch, or the hole doesn't drain all day, don't use graywater to irrigate this area. Try another location to see if the drainage is better. If you irrigate an area that does not have adequate drainage, you could have ponding and runoff. Plants could also be damaged by water-logged soil, so make sure to irrigate only well-drained soils, or amend your soil by adding compost to improve drainage.

Once you know how many gallons per day your home produces, have identified your soil type, and know that water drains well in the area you wish to irrigate, calculate the irrigation area needed to ensure proper drainage of graywater.

STEP 3: Calculating your *Irrigation Field Area*

To calculate your *irrigation field* area, you will need the Estimated Graywater Flow per day (gpd) calculated in Step 1 and the soil type determined in Step 2.

Find your soil type in Table 1 to the right and use the area indicated for your soil type. Multiply the gpd by the area to obtain the minimum area for your irrigation field. Note: your irrigation field can be larger than the calculated area, but not smaller.

Soil Type	Area (ft ²) per Gallon of Graywater (gpd)
Sand	.25
Sandy Loam	.4
Sandy Clay	.6
Clay	.9

Example: Total Estimated Graywater Flow per day = 60 gpd
Soil Type = Sand
Irrigation Field Area = 60 gpd x .25 ft² / gpd = 15 ft²

Protecting Groundwater

Graywater must be discharged a minimum of three feet above the groundwater table. If you don't know how deep the groundwater is beneath your property, you can check by digging a hole three feet deep. If no water enters the hole, then it is safe to irrigate the area with graywater. If water enters the hole, the groundwater table is too shallow, and graywater may not be used for irrigation. If you dig a hole to check the depth to groundwater, do so during the irrigation season, as this is the time you'll be using graywater. During the rainy months, with any signs of ponding or runoff from rainfall, or in places where the groundwater table rises, all graywater systems must be shut off.

Setback Requirements: Where Not to Put Your Graywater

Your graywater system should irrigate plants without causing problems for you or your neighbors. A setback is a required distance between your graywater system and specific landmarks. The purpose of setbacks is to avoid potential problems caused by nearby land uses. For example, you will need to keep graywater a certain distance from your house to avoid damaging its foundation, from your neighbor's yard to maintain good neighborly relations, and from creeks to prevent contamination of freshwater. Table 2 lists setback requirements in Mendocino.

Table 2. Required Setbacks for Graywater Systems in Mendocino County

Minimum Horizontal Distance from	Irrigation Field (ft)	Storage Tank (ft)
Building structures (not including porches, steps, covered walkways, patios, driveway)	2	5
Private property lines	1.5	5
Water supply wells	100	50
Streams and lakes	100	50
On-site domestic water service line	0	5
Pressurized public water main	10	10
Water table	3 feet above ¹	NA
Retaining wall²	2	NA

Notes: Setbacks from the California Graywater Code, Chapter 16A, Table 1, unless otherwise indicated.

1. A test hole 3 feet deep without water can demonstrate that the site is far enough above the groundwater table. The graywater system must be shut off in the rainy season.
2. Requirement specific to Mendocino.

References

California Graywater Code: http://www.hcd.ca.gov/codes/shl/Preface_ET_Emergency_Graywater.pdf

Cohen, Yorem, 2009. Graywater—A potential source of water. UCLA Institute for the Environment. Available at <http://www.ioe.ucla.edu/reportcard/article.asp?parentid=4870>.

Alameda County Waste Management Authority and Alameda County Source Reduction and Recycling Board, 2010. Bay-Friendly Gardening. Available at <http://www.stopwaste.org/home/index.asp?page=8>.

Thein, S.J., 1979. A Flow Diagram for Teaching Texture by Feel Analysis. *Journal of Agronomic Education*, 8:54-55.



Mendocino County Planning & Building Services
pbs@co.mendocino.ca.us
 860 North Bush Street, Ukiah CA 95482
 (707) 234-6650
 120 West Fir Street, Fort Bragg CA 95437
 (707) 964-5379
www.co.mendocino.ca.us/planning

Mendocino County Environmental Health
 860 North Bush Street, Ukiah CA 95482
 (707) 234-6625
 120 West Fir Street, Fort Bragg CA 95437
 (707) 961-2714
www.co.mendocino.ca.us/hhsa/chs/eh/landuse.htm